

PG-5H(PC Interface Cable Kit) / PG-5G(Programming Interface Cable)

The PG-5H comes with both of the "Data communications cable" (for audio in/out) and the "Serial communications cable" (for PC RS-232C serial port).

Both of these two cables are required for EchoLink sysop mode (node station) operation.

The PG-5G comes with the "Serial Communications Cable" (for PC RS-232C serial port).

The "Serial communications cable" is required for the Memory Control Program MCP-2A.

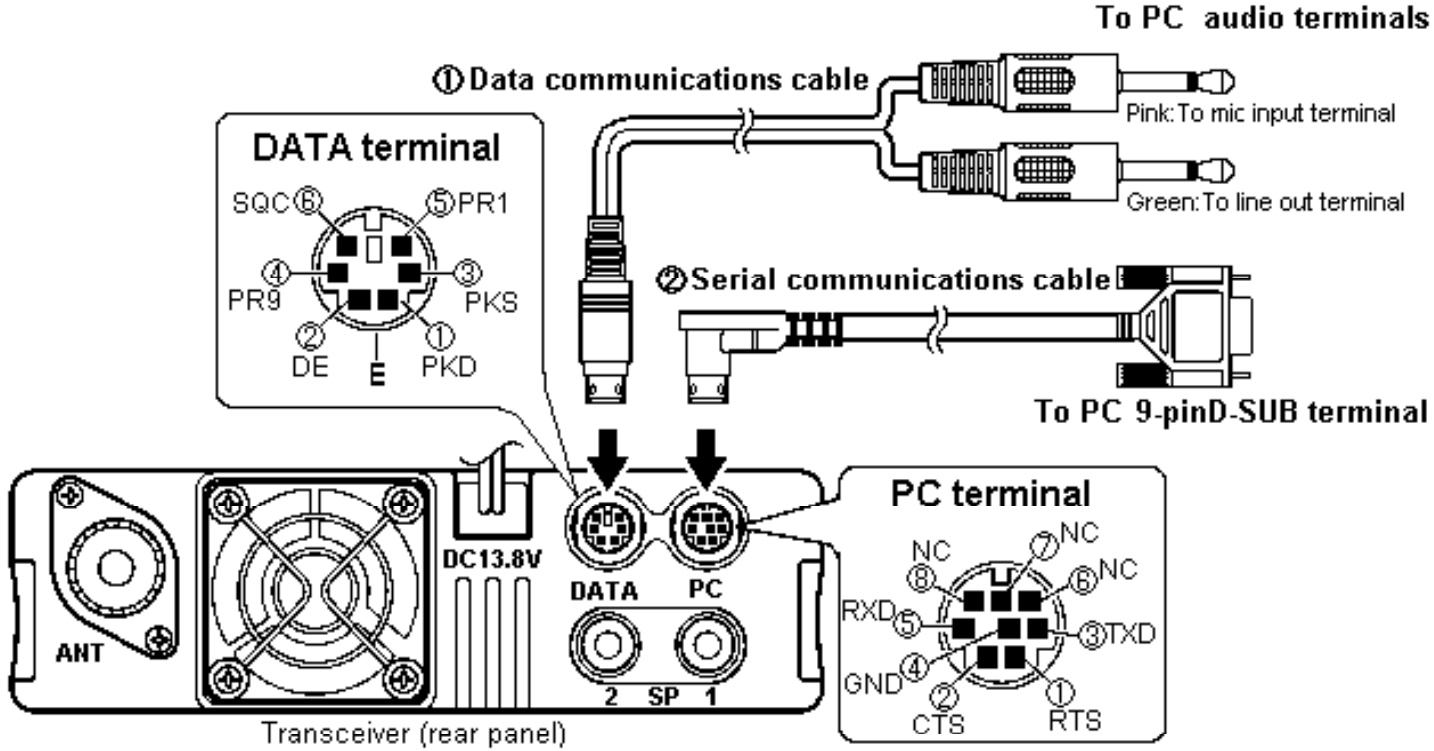

Data communications cable (for audio in/out) pin configuration

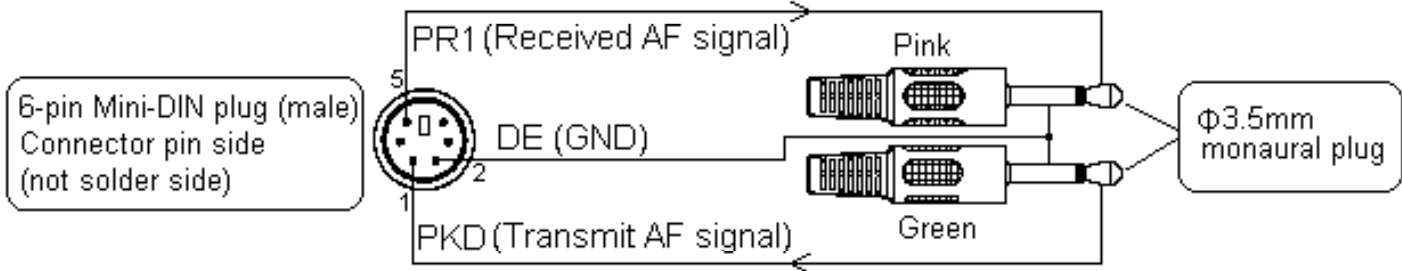

Serial communications cable (for PC RS-232C serial port) pin configuration

