

Warranty

The Hallicrafters Company warrants each new radio product manufactured by it to be free from defective material and workmanship and agrees to remedy any such defect or to furnish a new part in exchange for any part of any unit of its manufacture which under normal installation, use and service discloses such defect, provided the unit is delivered by the owner to our authorized radio dealer from whom purchased, wholesaler, or service center, intact, for examination, with all transportation charges prepaid within ninety days from the date of sale to original purchaser and provided that such examination discloses in our judgment that it is thus defective.

This warranty does not extend to any of our radio products which have been subjected to misuse, neglect, accident, incorrect wiring not our own, improper installation, or to use in violation of instructions furnished by us, nor extend to units which have been repaired or altered outside of our factory, nor to cases where the serial number thereof has been removed, defaced or changed, nor to accessories used therewith not of our own manufacture.

Any part of a unit approved for remedy or exchange hereunder will be remedied or exchanged by the authorized radio dealer or wholesaler without charge to the owner.

This warranty is in lieu of all other warranties expressed and no representative or person is authorized to assume for us any other liability in connection with the sale of our radio products.

622

94X ~~551~~

installation and operating instructions for model S-38A radio receiver

FEATURES

AC/DC OPERATION

AM BROADCAST 550 KC - 1650 KC

SHORT WAVE BROADCAST 1700 KC - 31 MC

DIRECT READING DIAL

SPREAD BAND TUNING

CODE OR VOICE RECEPTION

HEADSET CONNECTION



94X475

550

the hallicrafters co.

MANUFACTURERS OF RADIO AND ELECTRONIC EQUIPMENT, CHICAGO 26, U. S. A.

INSTALLATION AND OPERATING INSTRUCTIONS

RADIO RECEIVER MODEL S-38A



42X809

Fig. 1. Radio Receiver Model S-38A

DESCRIPTION

The Model S-38A radio receiver is a table model all-wave superheterodyne receiver capable of receiving all of the broadcasting services between 540 kilocycles (KC) and 31 megacycles (MC) in four overlapping bands as follows:

FREQUENCY COVERAGE

BANDS	*FREQUENCY RANGE	**TYPE OF RECEPTION
1	550 KC - 1650 KC	AM/CW
2	1.7 MC - 5.1 MC	AM/CW
3	5 MC - 14.5 MC	AM/CW
4	13 MC - 31 MC	AM/CW

* First and last dial calibration.

** AM - Amplitude Modulation CW - Code

The four bands or frequency ranges of the receiver are selected by the BAND SELECTOR. Four individual dial scales permit the frequency of reception to be read directly from the general coverage dial. Any narrow range of frequencies in the entire frequency spectrum covered by the receiver may be spread out electrically with the BAND SPREAD control. This feature provides more desirable tuning in the short wave broadcast ranges and particularly in the amateur bands. The general coverage dial setting for the amateur bands is shown on the dial scale (Heavy black bars) for convenience in setting up the receiver for amateur band reception.

Speaker or headset reception is available at the operator's discretion. The selection of each is made by a slide switch located on the panel. The speaker unit is built into the cabinet, the headset is plugged into the pin jack receptacles located on the rear chassis apron.

The AM/CW switch permits reception of either radio telephone or c-w code signals.

The RECEIVE/STANDBY switch permits the operator to disable the receiver for short standby periods yet maintain the tube heaters at operating temperature for immediate operation.

The receiver normally operates from a 105-125 V. DC (Direct Current) or 60 cycle AC (Alternating Current) power source. To place the receiver in operation it is merely necessary to connect a suitable antenna to the antenna terminals located on the rear chassis apron and plug the power plug into the wall outlet. Refer to the installation details that follow especially to the paragraph on "POWER SOURCE", before connecting the receiver to the wall outlet and avoid unnecessary and perhaps costly repairs.

INSTALLATION

UNPACKING - Check all shipping tags and labels for instructions before removing or destroying them.

LOCATION - The receiver is equipped with protective feet for table top or shelf mounting. Avoid excessively warm locations such as outlets for the heating system or recessed locations which prevent circulation of air. If the receiver is placed with its back to the wall, leave about an inch or two of clearance between the back of the cabinet and the wall for proper ventilation.

POWER SOURCE - The receiver operates from a 105-125 volt, 60 cycle AC (Alternating Current) or 105-125 volt DC (Direct Current) source. Power consumption is approximately 30 watts. The receiver will not operate from a 25-cycle AC source directly. If in doubt as to the voltage and frequency rating of your power source, contact the local power company representative to avoid costly repairs. If the receiver does not respond after a one minute warm-up period when operating from a direct current (DC) source, the power plug may have to be reversed at the wall outlet to obtain proper polarization.

Operation from a 220-volt AC/DC source may be had by using a special line cord adapter available as an accessory. Hallicrafters part 87D1566.

ANTENNA - A three terminal strip is provided on the rear chassis apron for antenna connections. The terminals are marked "A1", "A2", and "G". A jumper bar is normally connected between terminals "A2" and "G" for single wire antenna systems and unbalanced antenna transmission lines. For doublet antenna installations using a balanced transmission line, the jumper between "A2" and "G" is disconnected. A ground connection, when used, is connected to terminal "G".

Single Wire Antenna - If a single wire antenna installation is to be used, connect the jumper bar between antenna terminals "A2" and "G". A single wire antenna of about 50 to 100 feet long (including lead-in) is then connected to terminal "A1". Erect the antenna as high and free from surrounding objects as possible. A good ground connection generally improves reception when using this type of antenna. The water pipe makes a very effective ground.

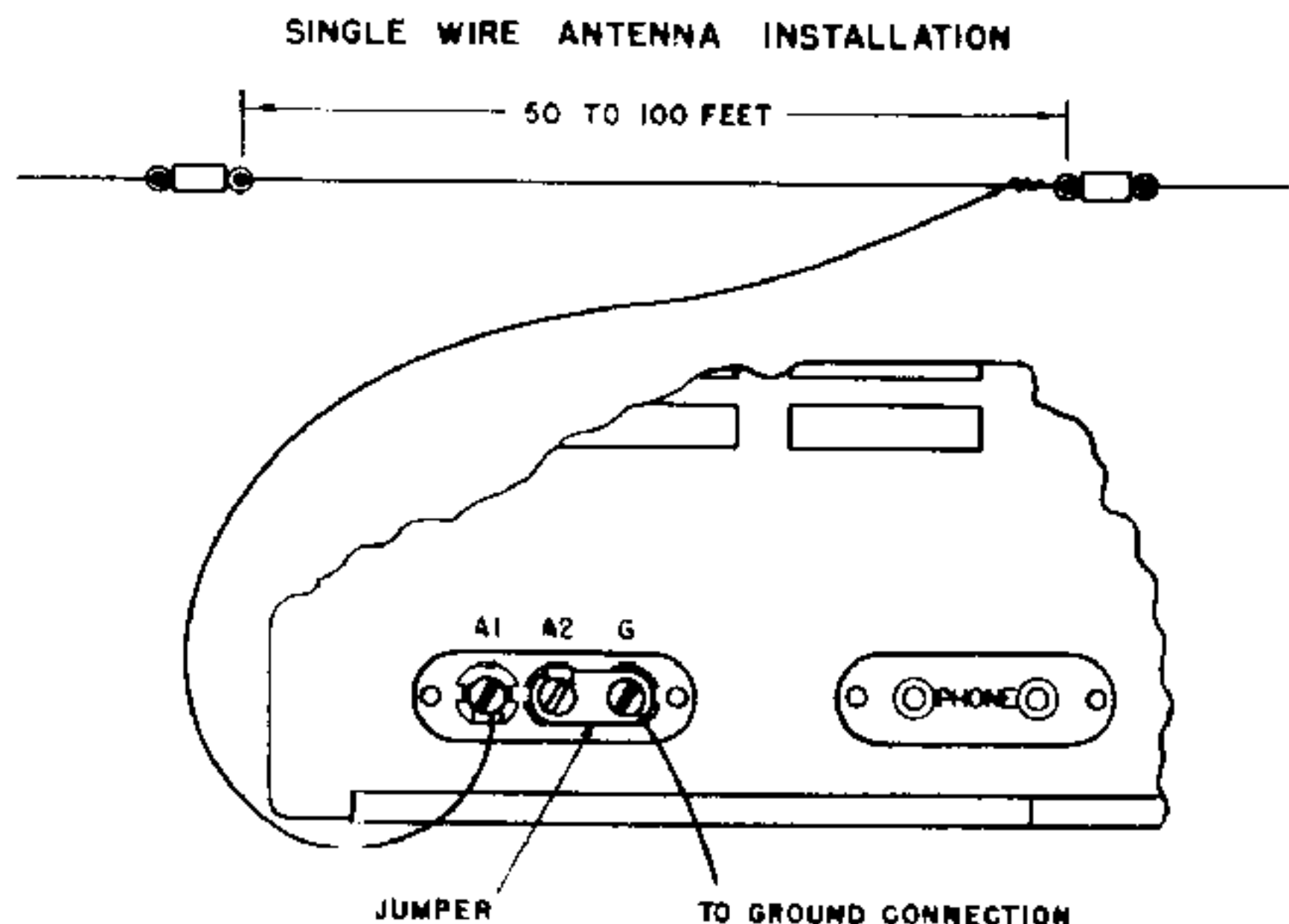

Fig. 2. Single wire antenna installation.

Doublet Antenna - The doublet antenna system is recommended for the higher frequency bands especially where maximum signal to noise is required over a relatively narrow range of frequencies. The transmission line from the antenna is connected to terminals "A1" and "A2". If a concentric line with a grounded outer conductor is used, connect the inner conductor to terminal "A1", the outer conductor to terminal "A2" and connect the jumper bar between terminals "A2" and "G".

The overall length (feet) of a doublet antenna may be determined by dividing the constant 468 by the desired frequency in megacycles.

Keep in mind that this type of antenna is directional broadside to its length and should be so oriented if maximum pickup from a given direction is desired.

**DOUBLET ANTENNA INSTALLATION
USING TWISTED PAIR LEAD-IN**

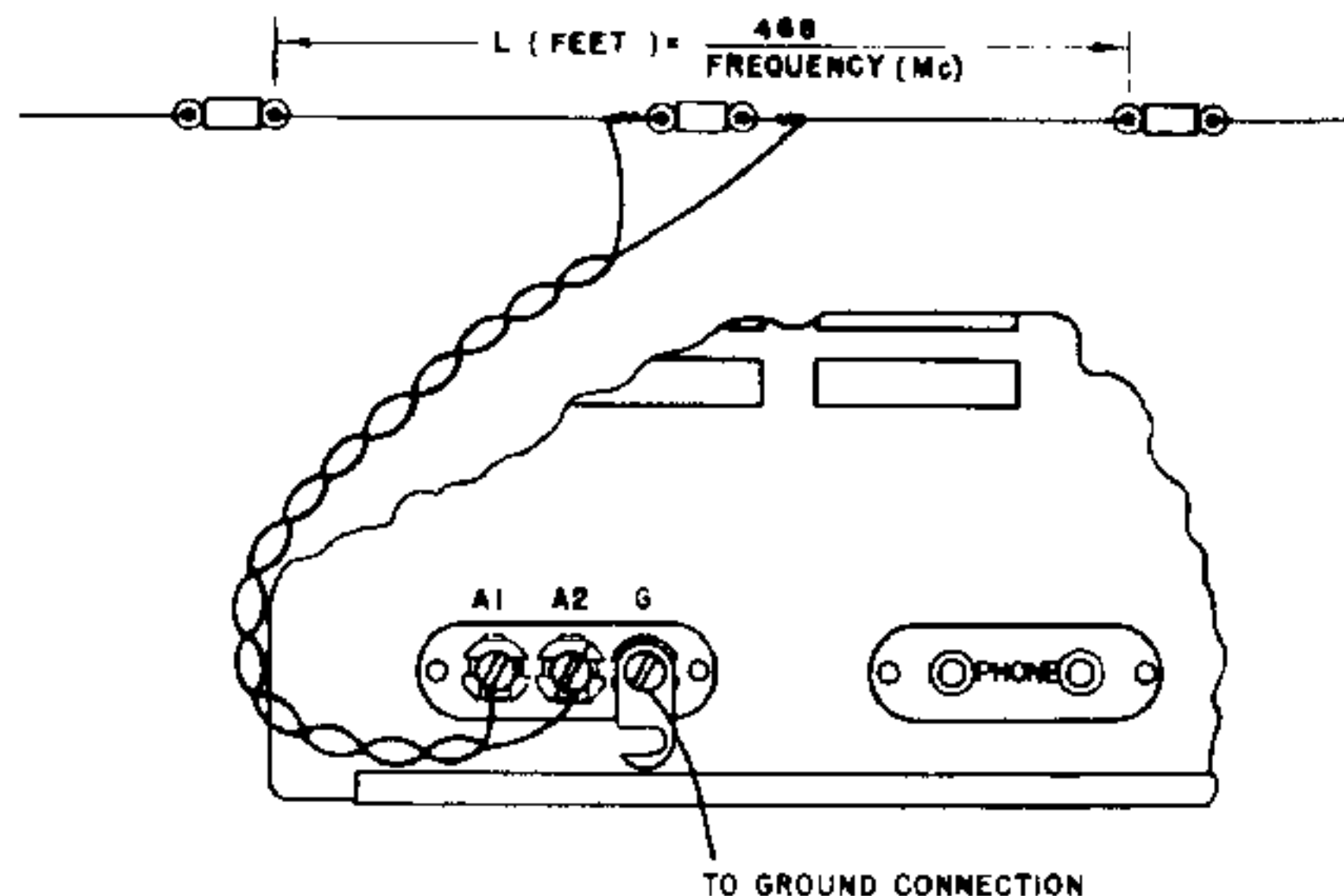

Fig. 3. Doublet antenna installation.

HEADSET CONNECTION - A pair of pin jacks are provided at the rear chassis apron for the headset phone tips. Any headset having a working impedance of 500 to 2,000 ohms may be used successfully with this receiver. To place the headset circuit in operation, set the SPEAKER/PHONES switch at PHONES.

OPERATION

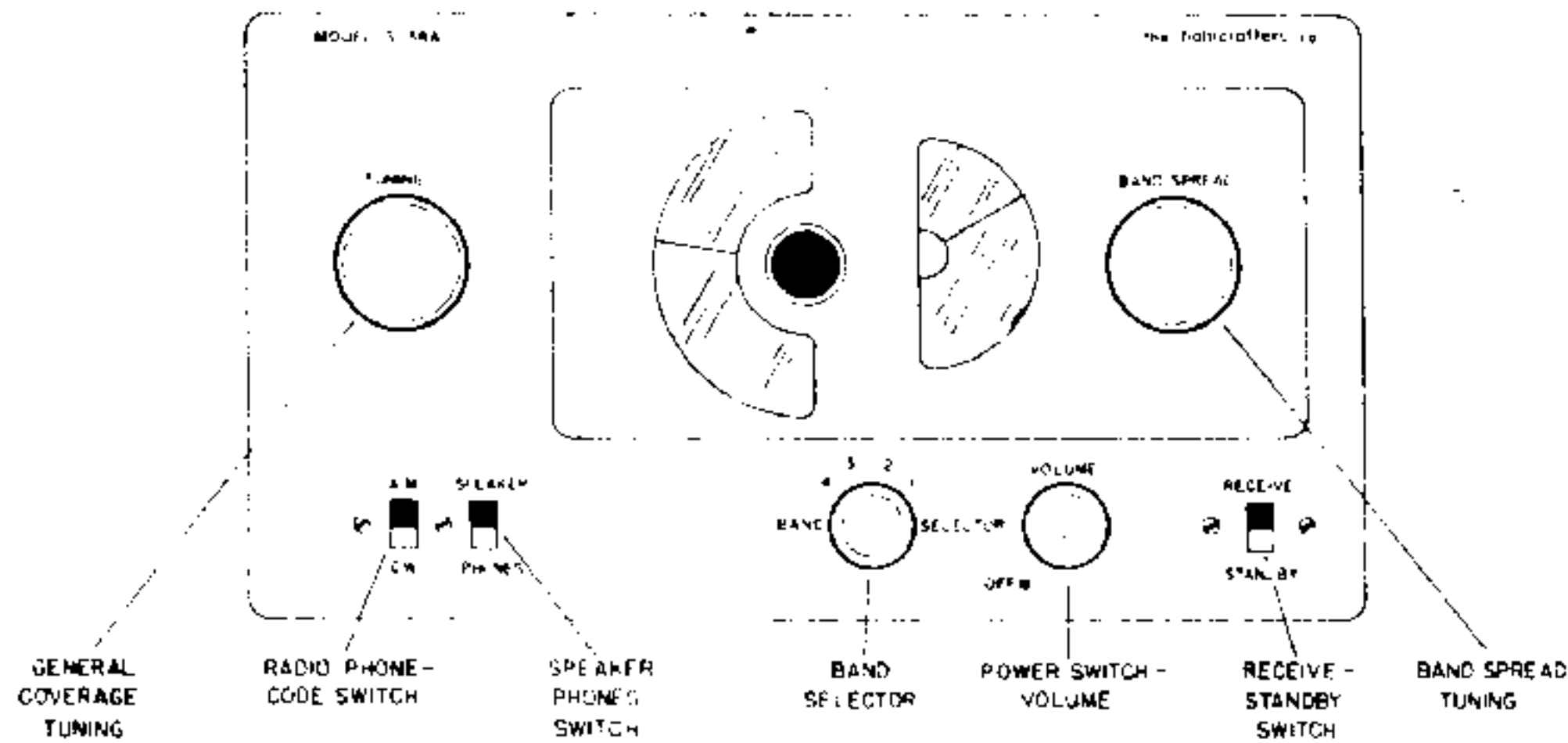

FIG. 4. Location of controls.

GENERAL BROADCAST RECEPTION - For regular broadcast entertainment purposes, set the **BAND SELECTOR** at 1, the **AM/CW** switch at **AM**, the **SPEAKER/PHONES** switch at **SPEAKER** and the **RECEIVE/STANDBY** switch at **RECEIVE**. Turn on the receiver with the **VOLUME** control by turning it clockwise. Use the **TUNING** control and **VOLUME** control in the usual manner, tuning for the loudest, clearest reception to obtain top performance from the receiver. When operating the receiver from a 115 V. DC outlet allow about a minute for warm-up. If the receiver doesn't respond after a reasonable warm-up period, reverse the power plug at the wall outlet to obtain proper polarity. In certain cases hum picked up from an AC outlet may be reduced by properly polarizing the power plug.

To turn off the receiver, turn the **VOLUME** control counter-clockwise until the power switch clicks.

SHORTWAVE RECEPTION - Radio telephone or voice reception in the short wave bands is accomplished as described above for general broadcast reception except that the **BAND SELECTOR** is set for ranges 2, 3 or 4. The frequency of reception is read from the dial scale which corresponds to the setting of the band selector knob. Any section of the dial or short range of frequencies may be spread out by tuning the stations with the **BANDSPREAD** control. Note that the general coverage dial calibration will be true only when the bandspread pointer is set at zero. Code reception is accomplished by setting the **AM/CW** switch at **CW** and tuning for the desired pitch when tuning in the station.

BANDSPREAD TUNING - To use the bandspread dial, set the dial pointer at zero, set the general coverage dial pointer at the high frequency limit of the range of frequencies to be covered and tune in the stations with the **BAND SPREAD** control. For example: - Assume that the 40 meter amateur band is to be covered. Set the **BAND SELECTOR** at 3, the general coverage dial at 7.3 mc and tune with the **BAND SPREAD** control. The use of the bandspread feature is similar for the reception of shortwave broadcast, etc. In this case the bandspread dial is first set at zero and the station or group of stations located on the general coverage dial. Then by setting the general coverage dial pointer slightly higher in frequency than the group, the bandspread control will tune through the range, spreading out the group of stations over a large portion of the bandspread dial scale.

RECEIVE/STANDBY SWITCH - This switch must be set at **RECEIVE** for normal operation. To disable the receiver for short stand-by periods set the switch at **STANDBY**. This leaves the heaters at operating temperature during standby periods and permits instant response when reception is again desired.

SPEAKER/PHONES - Normally this switch is set at **SPEAKER** for loud speaker reception. Setting the switch at **PHONES** switches the output circuit from the speaker to the headset output jacks located on the rear apron of the chassis.

SERVICE

TUBE REPLACEMENT - The tube types and their relative position in the receiver are shown in the illustration, Fig. 5. When installing a replacement tube, insert the center guide pin into the center hole of the tube socket; rotate the tube until the key on the guide pin drops into the notch in the socket hole; and push down until the base of the tube rests firmly on the socket.

Handle tubes with care as they are considered fragile and do not tolerate much mechanical abuse.

DIAL LAMP REPLACEMENT - Refer to Fig. 5 for the location of the dial lamp. To replace a defective lamp, reach in through the rear of the cabinet and unclip the dial lamp socket by compressing the side springs. The socket and defective lamp may then be brought out into the open for service.

Make replacements with 6-8 volt Mazda #47 (Brown bead) lamps.

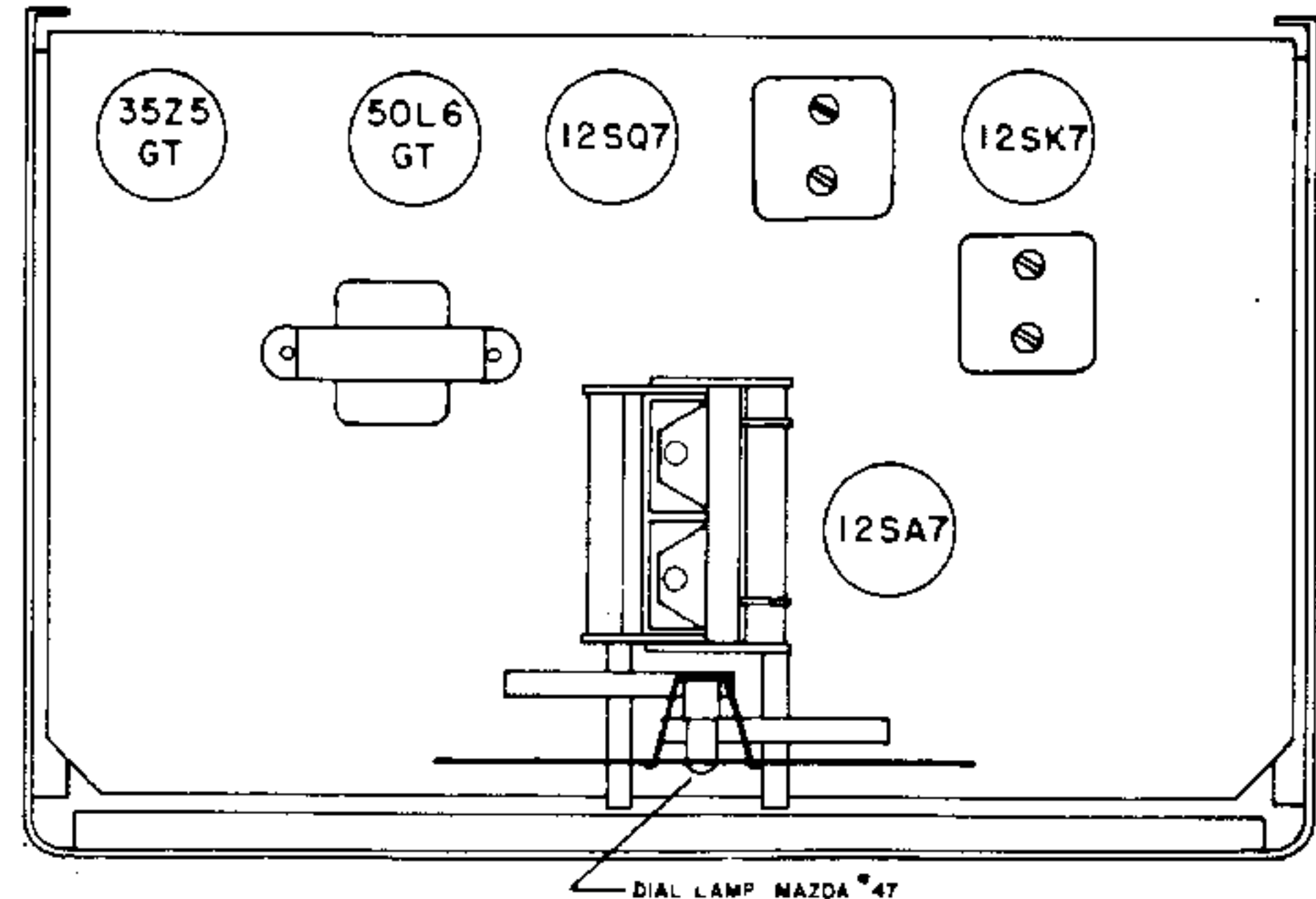

FIG. 5. Top view, location of tubes and dial lamp.

SERVICE OR OPERATION QUESTIONS - For further details regarding operation or servicing of the receiver, contact your dealer directly. Make no shipments directly to the factory before first writing for authorization and instructions. The factory cannot accept responsibility for unauthorized shipments.

the hallicrafters co.

FOR MODEL S-38A

AUG.
FORM 94
RUN N
SEE CHA
STAMP.

GENERAL

Tubes	Four plus rectifier.										
Speaker	5-inch PM.										
Voice Coil Impedance	3.2 ohms.										
Headset Output	Low impedance.										
Antenna	Provisions for external antenna with transmission line or single wire feed.										
Tuning	Manual										
Tuning Range	<table border="1"> <thead> <tr> <th>Band Selector Position</th> <th>Frequency Range</th> </tr> </thead> <tbody> <tr> <td>1</td> <td>550 kc - 1650 kc.</td> </tr> <tr> <td>2</td> <td>1.7 mc - 5.1 mc.</td> </tr> <tr> <td>3</td> <td>5 mc - 14.5 mc.</td> </tr> <tr> <td>4</td> <td>13 mc - 31 mc.</td> </tr> </tbody> </table>	Band Selector Position	Frequency Range	1	550 kc - 1650 kc.	2	1.7 mc - 5.1 mc.	3	5 mc - 14.5 mc.	4	13 mc - 31 mc.
Band Selector Position	Frequency Range										
1	550 kc - 1650 kc.										
2	1.7 mc - 5.1 mc.										
3	5 mc - 14.5 mc.										
4	13 mc - 31 mc.										
Intermediate Frequency.....	455 kc.										
Power Supply.....	105-125 V. DC or 60 cycles AC.										
Power Consumption	30 Watts										



92X809

RESTRINGING DIAL CORD

To restring the general coverage tuning dial cord cut a 14-inch length of 30 lb. test dial cord and tie one end to the tension spring at position "1" on the diagram. Follow the sequence "1" through "15", and at position "15" stretch the tension spring and tie the cord securely.

To restring the band spread tuning dial cord, cut a 16-inch length of dial cord and follow the procedure as above, starting at position "A" on the diagram. Note that the tuning drive shafts are wrapped with two and a fraction turns of dial cord for proper traction.

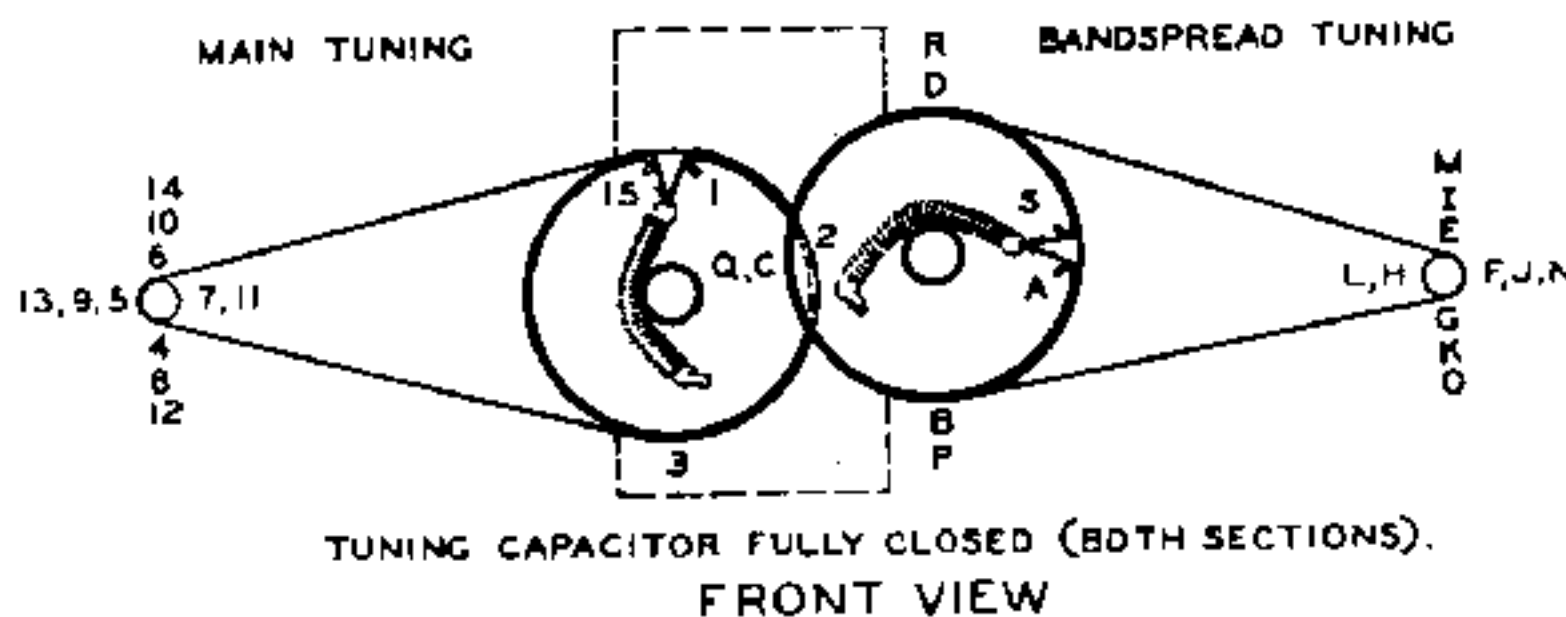

92X814

Fig. 1. Dial cable stringing procedure.

REPLACING LAMPS

Refer to Fig. 4, for the location of the dial lamp used in receiver. To gain access to the defective lamp, reach in through the rear of the cabinet (cover removed) and unclip the dial lamp socket by compressing the side springs. The socket may then be brought out into the open to change the defective lamp. Replace defective lamps with 6-8 V. Mazda #47 (Brown bead) lamps or equivalent.

ALIGNMENT PROCEDURE

Holes in the bottom cover permit minor adjustment of the oscillator and mixer stage trimmers, however for complete alignment, the chassis will have to be removed from the cabinet. To separate the chassis from the cabinet, remove the back cover and bottom plate. The chassis is fastened to the cabinet by four front panel screws located near the slide switches and two cabinet screws located at the bottom rear of the cabinet.

CAUTION - The four rubber grommets insulate the chassis from the cabinet. Check the condition of these grommets and replace if necessary.

The standard RMA dummy antenna specified in the alignment chart consists of a 200 mmf condenser in series with a 20 uh r-f choke which is shunted by a 400 mmf condenser in series with a 400 ohm carbon resistor.

Set the following controls before alignment.

AM/CW	Set at AM
SPEAKER/PHONES	Set at SPEAKER
VOLUME	Set at maximum
RECEIVE/STANDBY.....	RECEIVE
BAND SPREAD	Set at zero

For the settings of the remaining controls, see alignment chart.

ALIGNMENT CHART

Step	Dummy Antenna	Signal Generator Coupling	Signal Generator Frequency	Band Selector Setting	Receiver Dial Setting	Adjust	Remarks
1	.01 mfd cap.	Stator plates, front section of tuning gang.	455 kc	1	1000 kc	A,B,C,D	Adjust for max. audio output at speaker voice coil. Use just enough signal generator output to obtain a 50 mw signal level.
2**	See step 1	See step 1	455 kc (No modulation)	1	1000 kc	E	Set the AM/CW switch at CW. (Reset the switch at AM when step 2 is completed.) Correct BFO operation is obtained by varying the coupling between the wire "E" and the 12SK7 tube grid and plate terminals (Pins 4 and 8.) Pushing the wire toward the grid terminal increases the capacity and the strength of the beat.
3	Std. RMA dummy	High side to term. A1 on antenna strip. Jumper wire between A2 and G	30 mc	4	30 mc	*F,G	Max. output as in step 1.
4	Std. RMA dummy	See step 3.	14 mc	3	14 mc	*H,J	Max. output as in step 1.
5	Std. RMA dummy	See step 3	5 mc	2	5 mc	*K,L	Max. output as in step 1.
6	Std. RMA dummy	See step 3	1500 kc 600 kc	1	1500 kc 600 kc	*M,N *P	Max. output as in step 1.

* Note - Calibration adjustments.

** Note - This step is generally unnecessary. Adjustment should be made if a weak beat note is obtained on strong c-w signals indicating lack of coupling between wire "E" and tube socket wiring.

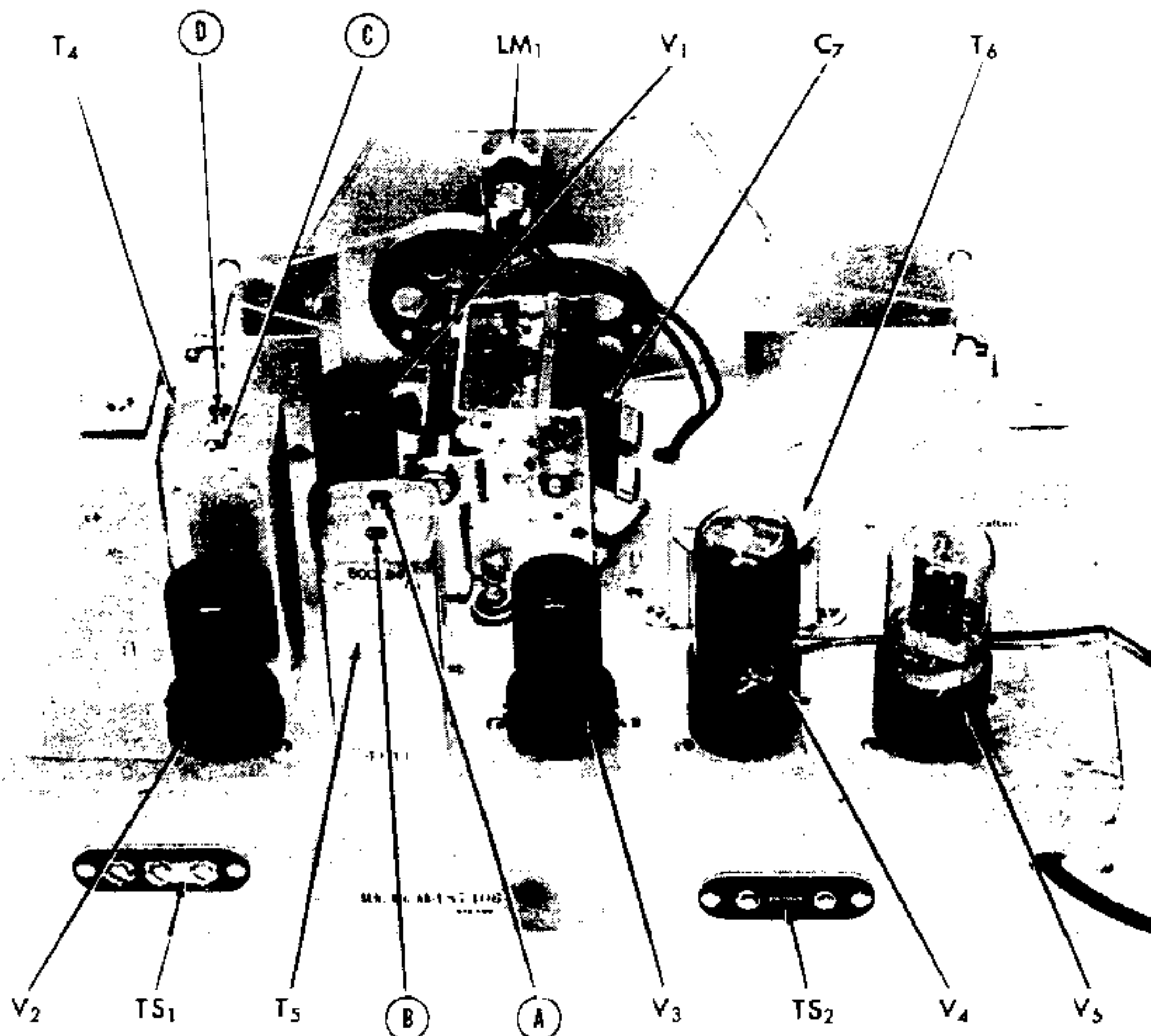

Fig. 2. Top view, alignment adjustments and component location

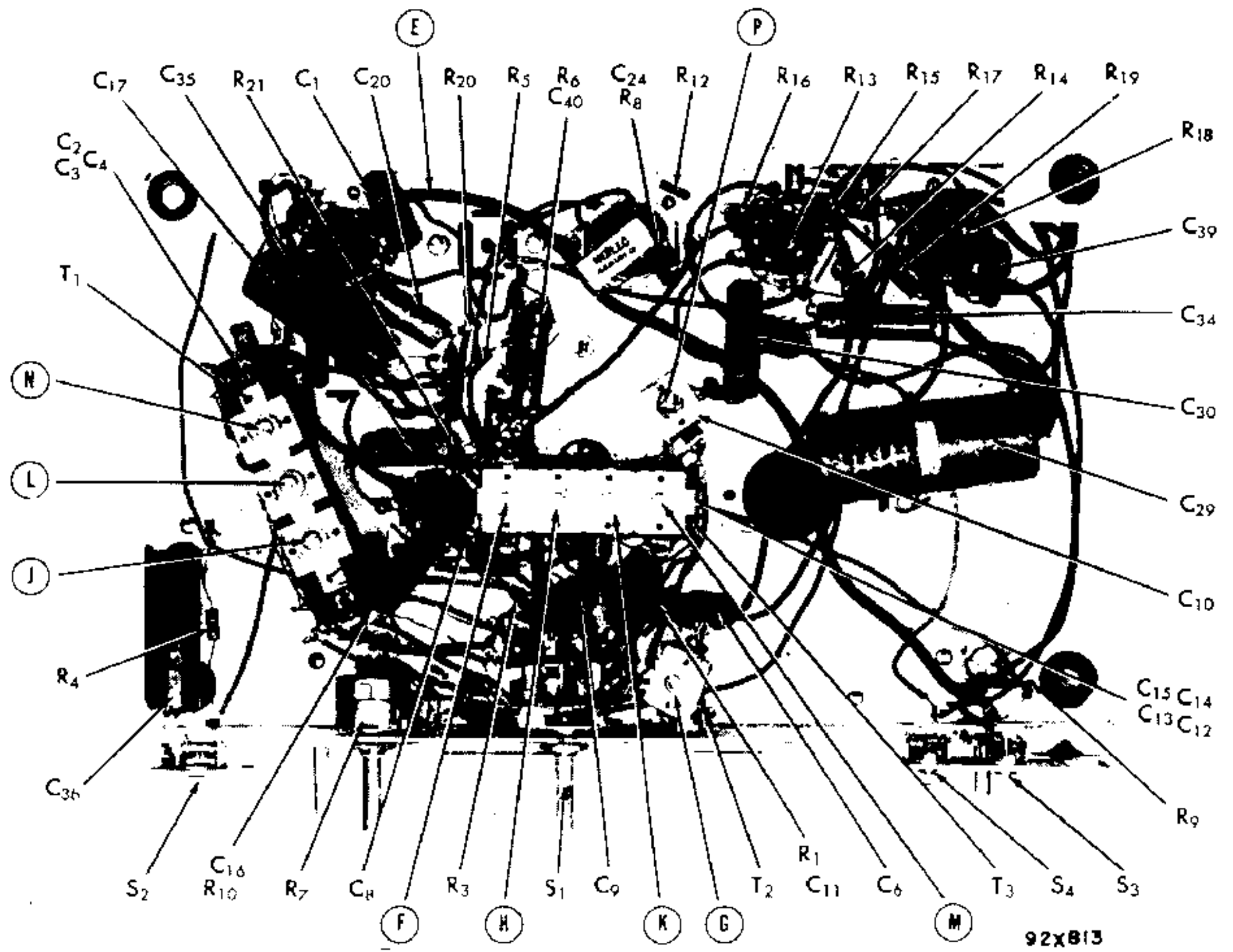

Fig. 3. Bottom view, alignment adjustments and component location

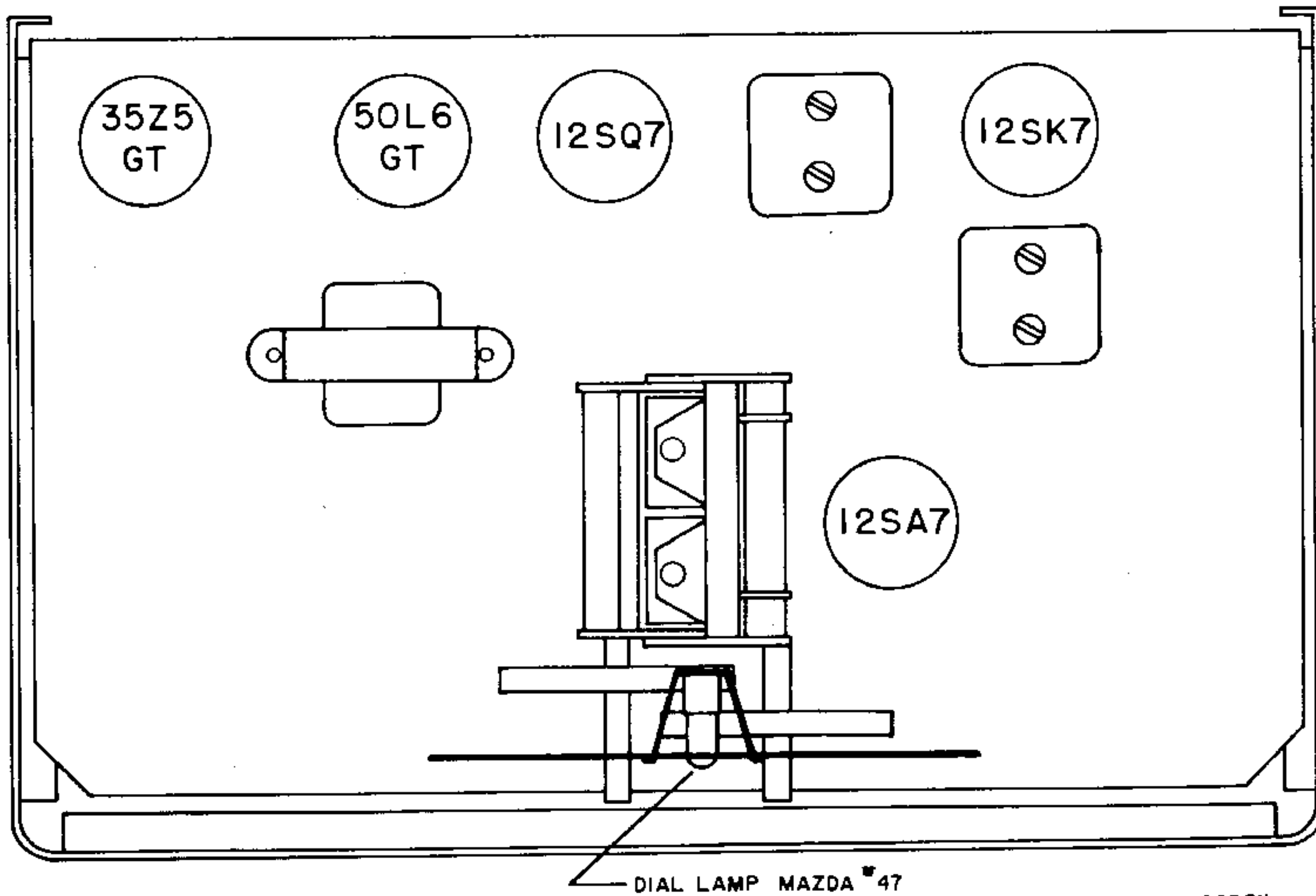
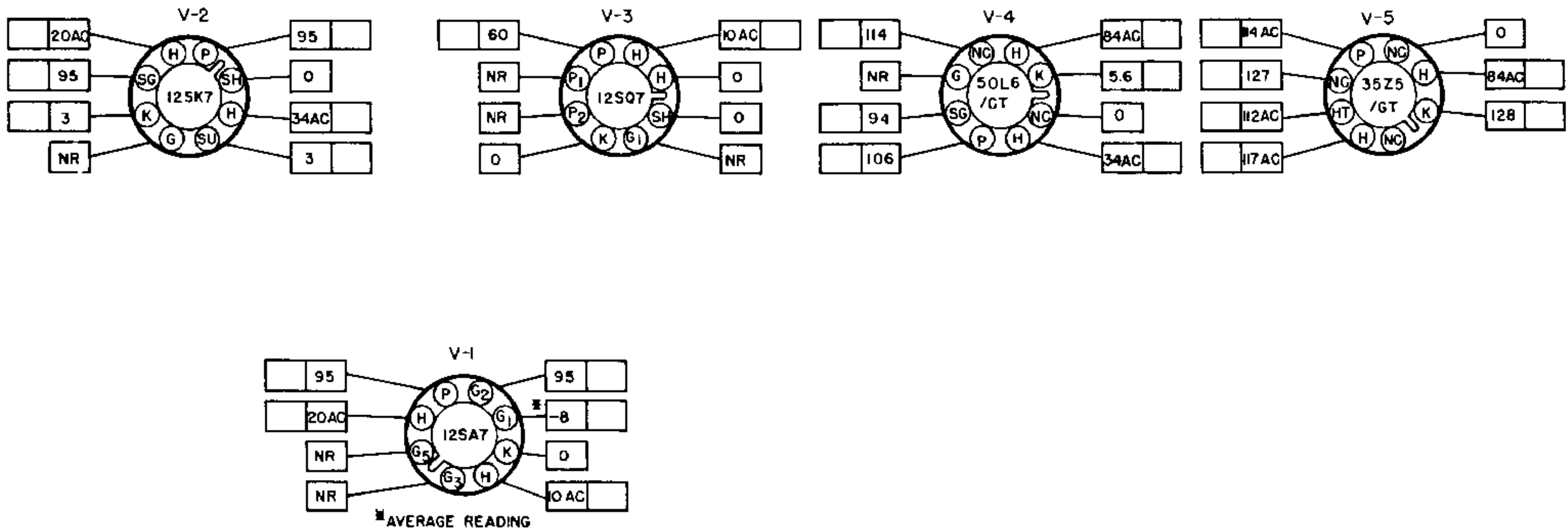

Fig. 4. Top view, location of tubes and dial lamp.

SERVICE PARTS LIST

Ref. No.	Description	Manufacturer's Part Number	Ref. No.	Description	Manufacturer's Part Number
CONDENSERS			SWITCHES		
C-1,40	.01 mfd. 600 V., tubular	46AY103J	S-1	Bandswitch assembly	60A240
C-2,3,4	Trimmers, adjustable (Part of transformer T-1)		S-2	Switch, slide; RECEIVE - STANDBY	60A244
C-5	Trimmer, adjustable (For transformer T-2)	44A039	S-3,4	Switch, slide; SPST; AM-CW & SPEAKER-PHONES	60A243
C-6	2700 mmf 500 V, mica	47X30A272J	S-5	Switch, power (Part of VOLUME control R-7)	
C-7	Tuning condenser, 2 sections	48C162-1			
C-8	220 mmf 500 V, mica	47X20A221K			
C-9	3000 mmf 500 V, mica	47X30A302J			
C-10	Padder, adjustable (Band 1)	44A349			
C-11	2200 mmf 500 V, mica	47X30A222J			
C-12,13,14	Trimmers, adjustable (Part of transformer T-3)				
C-15	.02 mfd 400 V, tubular	46AW203J	PL-1	Line cord	87A078
C-16	.25 mfd 200 V, tubular	46AT254J	TS-1	Terminal strip, antenna	88A032
C-17,36	.05 mfd. 200 V, tubular	46AU503J	TS-2	Headset, jack	88A071
C-20,35	Capacitor, composite; 5,000, 2X220, and 2000 mmf; 500 V.; ceramic	46A151		Socket, octal (tube)	6A250
C-24	40-30-30 mfd 150 V, 20 mfd. 25 V, electrolytic	45B091		Socket, dial light	86A011
C-29	.02 mfd 600 V, tubular	46AY203J			
C-30,34	470 mmf 500 V, mica	CM20A471M			
C-39	Wiring capacity.				
C-41,42					
RESISTORS			TUBES, RECTIFIERS AND LAMPS		
R-1,13,20	470,000 ohms 1/2 watt, carbon	23X20X474M	V-1	Type 12SA7, mixer/oscillator	90X12SA7
R-2	22,000 ohms 1/2 watt, carbon	23X20X223M	V-2	Type 12SK7, i-f amplifier & BFO	90X12SK7
R-3	47 ohms 1/2 watt, carbon	23X20X470M	V-3	Type 12SQ7, detector & 1st audio	90X12SQ7
R-4	390 ohms 1/2 watt, carbon	23X20X391K	V-4	Type 50L6GT, audio power amplifier	90X50L6GT
R-5	2.2 megohms 1/2 watt, carbon	23X20X225M	V-6	Type 35Z5GT, rectifier	90X35Z5GT
R-6	47,000 ohms 1/2 watt, carbon	23X20X473M	LM-1	Lamp, dial light, Mazda #47	39A004
R-7	Resistor, variable; VOLUME control	25B094			
R-8	10 megohms 1/2 watt, carbon	23X20X106M			
R-9	470 ohms 1/2 watt, carbon	23X20X471K			
R-10	10,000 ohms 1/2 watt, carbon	23X20X103M			
R-12	220,000 ohms, 1/2 watt, carbon	23X20X224M			
R-14	150 ohms 1/2 watt, carbon	23X20X151K			
R-15	15 ohms 1/2 watt, carbon	23X20X150M			
R-16	1000 ohms 1/2 watt, carbon	23X20X102M			
R-17	220 ohms 1 watt, carbon	23X30X221M			
R-18,21	22 ohms 1/2 watt, carbon	23X20X220M			
R-19	330 ohms 1/2 watt, carbon	23X20X221M			
TRANSFORMERS AND COILS			MISCELLANEOUS		
T-1	Transformer, antenna stage, Bands 1, 2 and 3	51C821		Clip, coil mtg (For transformer T-2)	76A326
T-2	Transformer, antenna stage, Band 4	51B1015		Shaft, main tuning	74A244
T-3	Transformer, oscillator stage, Bands 1, 2, 3 and 4			Shaft, bandspread	74A245
T-4	Transformer, i-f amp. stage	50B183		Washer, spring (For main tuning and bandspread drive shafts)	4A043
T-5	Transformer, i-f amp. stage (diode)	50B184		Spring, retainer ("C" washer type)	75A062
T-6	Transformer, audio output	55A127	LS-1	Dial cord	38A019
				Spring, dial cord	75A012
				Pointer, main tuning	82A140
				Pointer, bandspread tuning	82A103
				Dial scale	83C321
				Knob, VOLUME control and BAND SELECTOR	15A049
				Knob, TUNING and BAND-SPREAD	15A047
				Speaker, PM	85C030
				Baffle, speaker	78B198
				Cabinet back	32C330
				Cabinet bottom	8C807
				Mounting foot, rubber	16A007



FRONT APRON
BOTTOM VIEW OF CHASSIS

1. SOCKET VIEWS ARE BOTTOM VIEWS.
2. ALL VOLTAGES ARE MEASURED BETWEEN TUBE SOCKET TERMINALS & CHASSIS, WITH ZERO SIGNAL INPUT.
3. LINE VOLTAGE—117 V. AC. AC VOLTAGES WILL BE DC VOLTAGES WHEN OPERATING FROM A DC SOURCE.
4. ALL VOLTAGES SHOWN ARE DC UNLESS OTHERWISE SPECIFIED.
5. DC VOLTAGES SHOWN WERE MEASURED WITH AN ELECTRONIC VOLTMETER.
6. "NC" NO CONNECTION. (VOLTAGES SHOWN FOR THIS TERMINAL ONLY WHEN TERMINALS ARE USED AS A TIE LUG.)
7. "NR" NOT READABLE. (READING GENERALLY MEANINGLESS)
8. SPACE PROVIDED FOR SERVICE METER READINGS.

Fig. 5. Tube socket voltage chart.

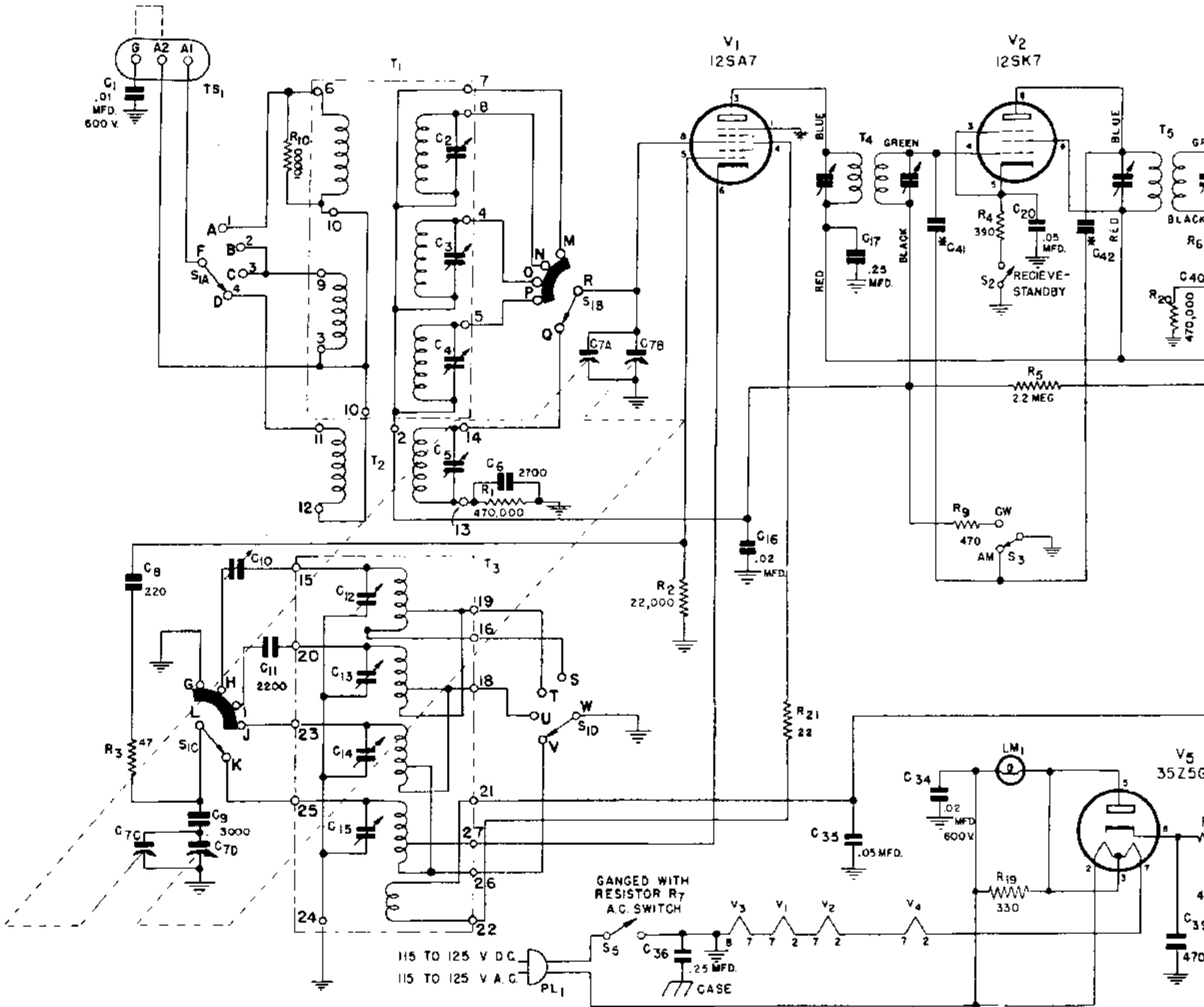

BANDSWITCH S1

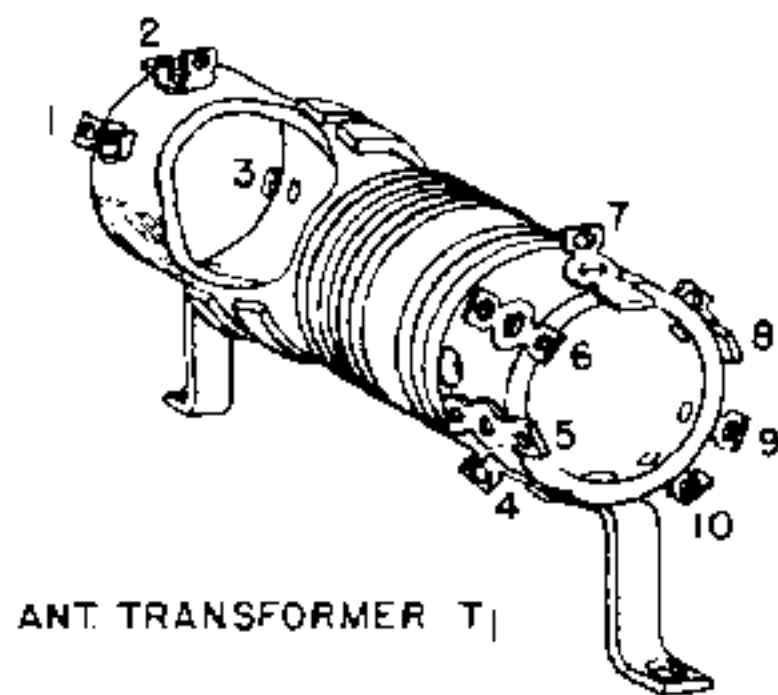
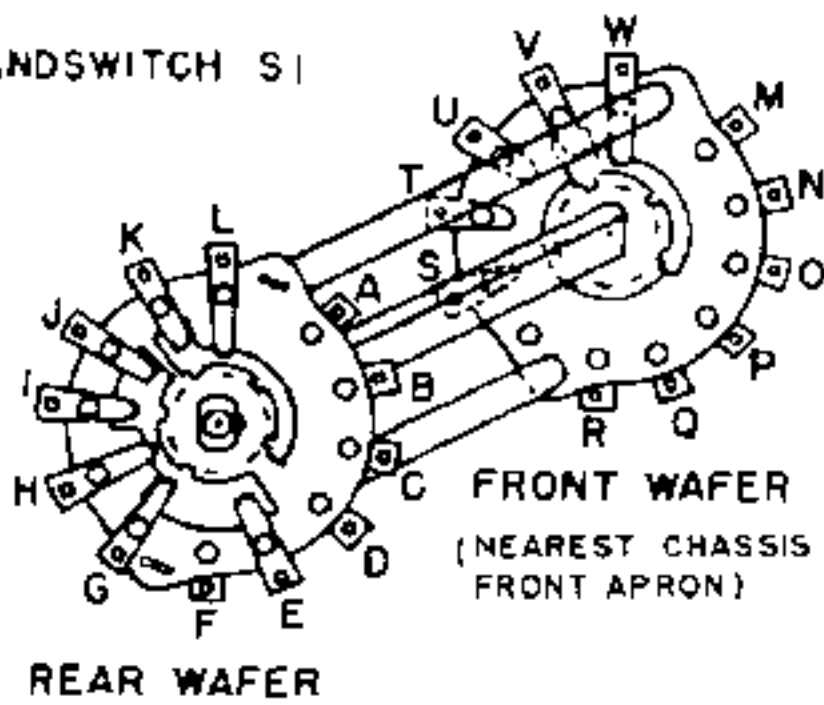

ANT TRANSFORMER T2

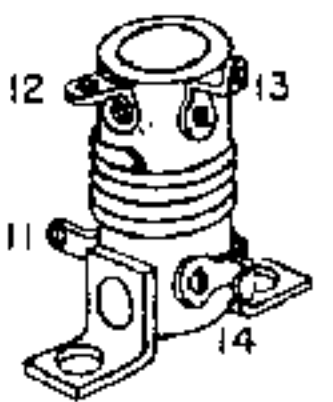

NOTE: DIMENSIONS & PROPORTIONS SHOWN IN PICTORIAL
BEEN EXAGGERATED FOR CLARITY OF TERMINAL

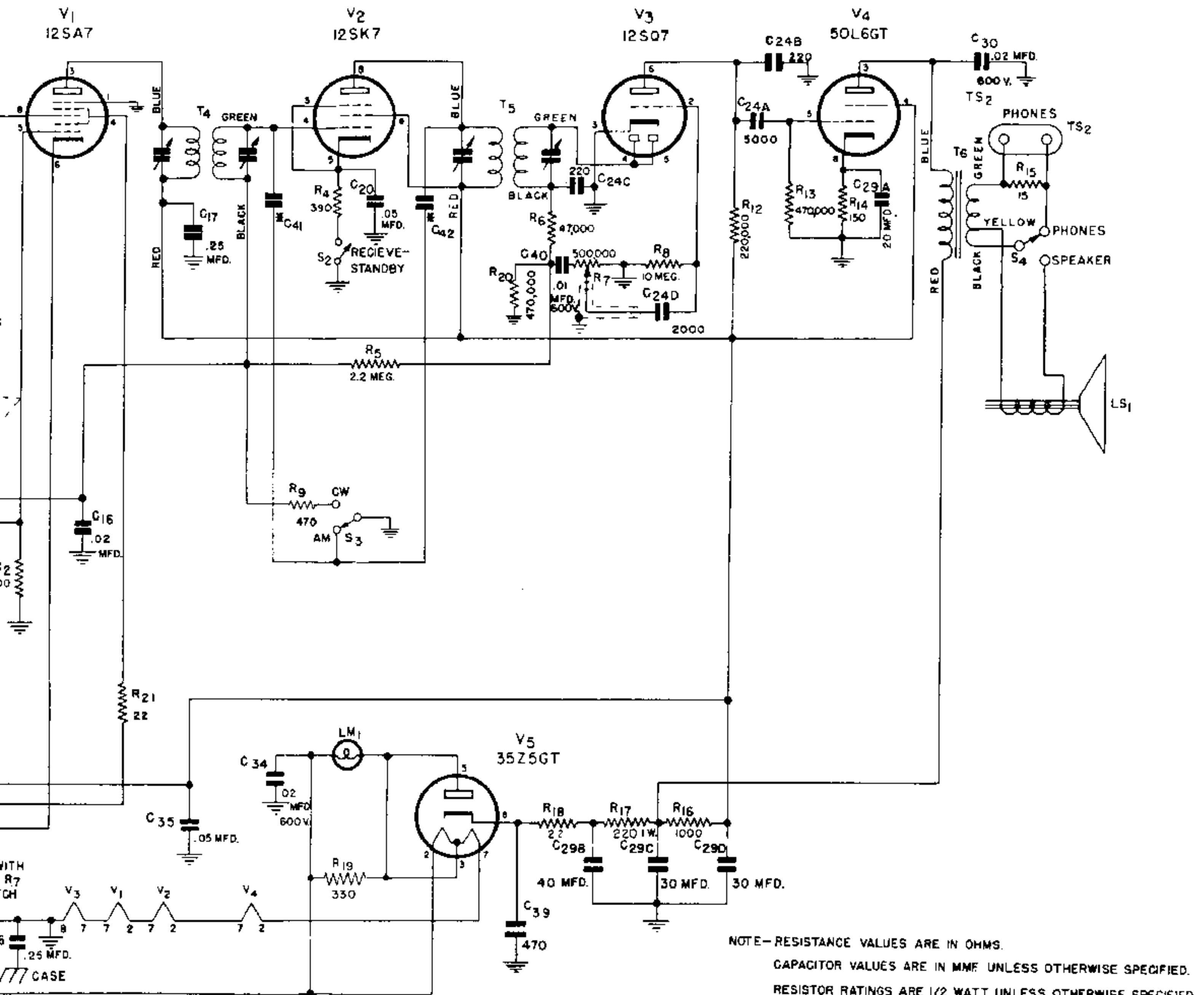

NOTE—RESISTANCE VALUES ARE IN OHMS.
 CAPACITOR VALUES ARE IN MMF UNLESS OTHERWISE SPECIFIED.
 RESISTOR RATINGS ARE 1/2 WATT UNLESS OTHERWISE SPECIFIED.
 *NOTE—CAPACITY C-41 & C-42 DUE TO PLACEMENT OF WIRE.
 NOTE— CHASSIS GROUND
 CABINET GROUND

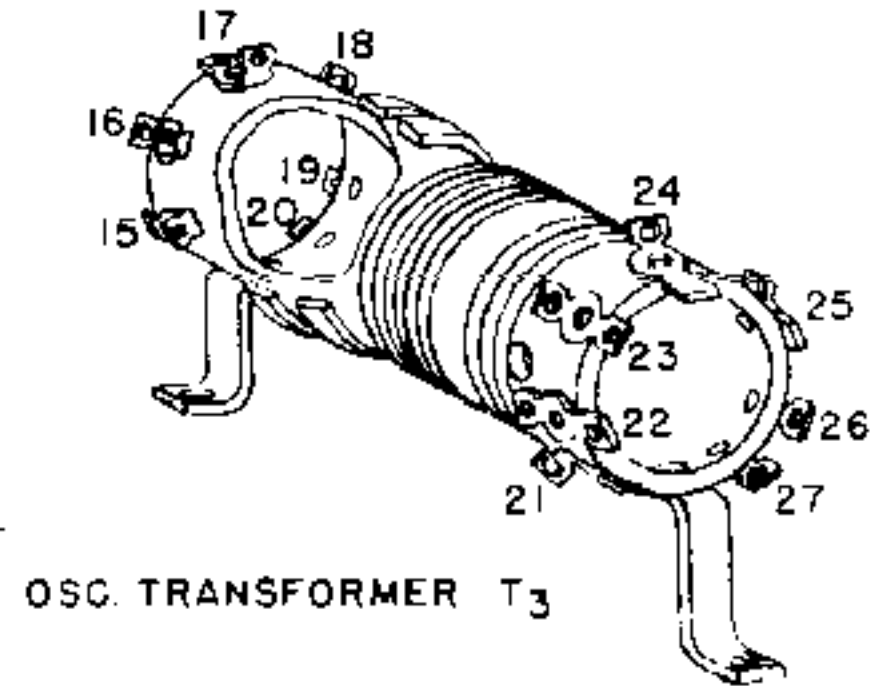
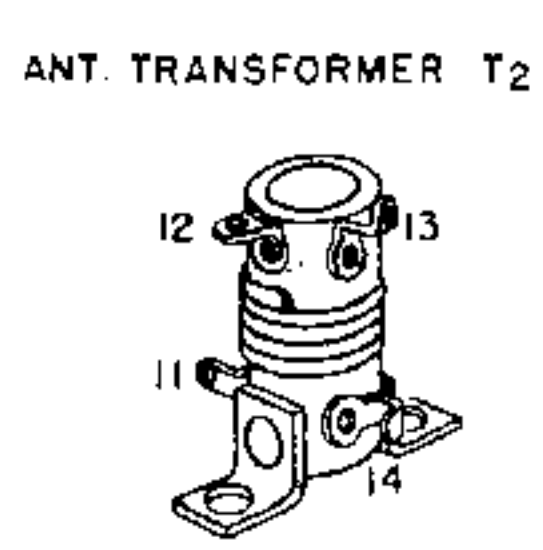
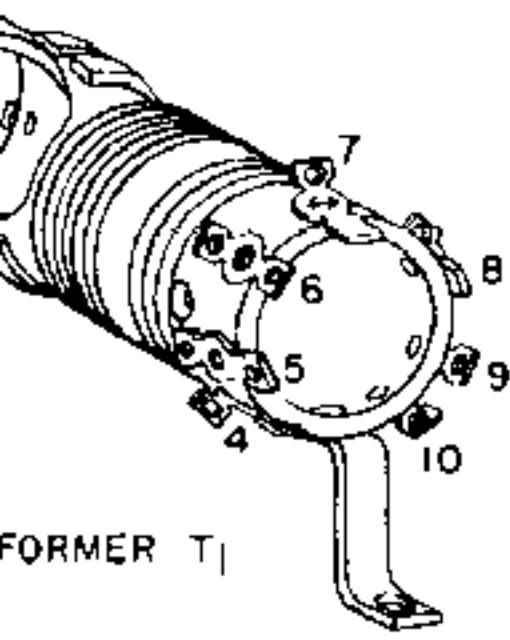

LAST CONDENSER SYMBOL C-42
 LAST RESISTOR SYMBOL R-21

DIMENSIONS & PROPORTIONS SHOWN IN PICTORIAL VIEWS HAVE BEEN EXAGGERATED FOR CLARITY OF TERMINAL LUG LOCATION.

Fig. 6. Schematic diagram.